

Precision Engineered Products and Systems



For Improving the Environment

A family of companies creating better working environments for you.

BUSCH

Precision-Engineered Products and Systems for Improving the Environment

BUSCH International designs, manufactures and supplies equipment that filters, cools and heats air for industrial use. **BUSCH** creates improved environments in motor rooms, computer rooms, and other enclosures housing electrical equipment. **BUSCH** also provides systems for corrosion protection, fugitive emissions control, evaporative cooling, oil mist collection, mill building ventilation and many other critical ventilation and air handling applications. **BUSCH** units typically feature heavy-duty welded construction and are typically factory preassembled and prewired.

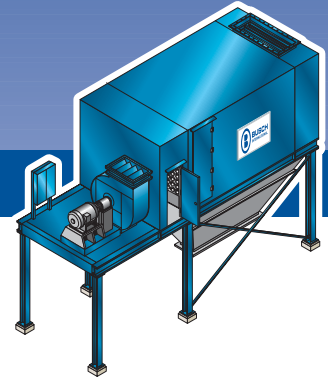

Ventilation/Particulate Filtration

MRV-80™ – Industrial air handling unit with self-cleaning tube filters ideally suited for large electrical equipment room ventilation.

Capacities: 10,000 to 62,500 cfm in a single packaged unit.

MRV-81™ – Heavy-duty air handling unit with self-cleaning cartridge filters.

Capacities: 10,000 to 80,000 cfm in a single packaged unit.

N-DUR-AIR™ – Rugged air handling unit with replaceable filters.

Capacities: 2,000 to 150,000 cfm in a single packaged unit.

WELD SMOKE COLLECTION – High capacity weld smoke collection units utilize self-cleaning cartridge filtration.

Sizes to 30,000 CFM

FUGITIVE EMISSIONS FILTRATION (FEF) – Designed to provide for cost effective solutions for high volume applications with low particulate concentrations. HEPA second stage filtration is optional.

DUST COLLECTION SYSTEMS – Pulse Jet and Reverse Air dust collection systems for melt shop and other metals industry related applications.



BUSCH International is recognized worldwide as providing Best Available Control Technology for the capture and collection of emissions produced by steel, aluminum and nonferrous rolling mills. **FUME-SHIELD™** systems **CONTAIN, CAPTURE, CONVEY, and CLEAN** contaminated air. **BUSCH** has designed and supplied more than two hundred **FUME-SHIELD™** systems with a combined airflow of over ten million cfm. **BUSCH** fume exhaust systems with EPA recognized hood designs provide high efficiency control of oil mist and fumes, efficiently removing liquid particles and vapor phase emissions from rolling mill, machining and other oil mist generating processes.

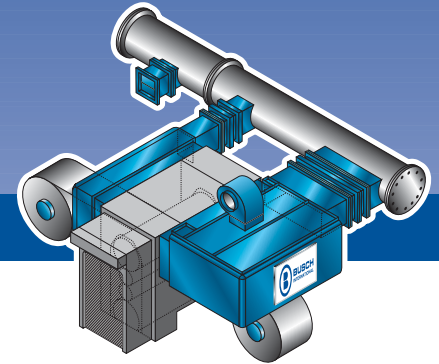

FUME-SHIELD™ Systems

JET-WALL™ – Air-curtain hoods provide enhanced fume capture efficiency for rolling mills and other process lines/machines. Hoods incorporate drip-resistant construction, and serve as first stage collection device.

STACK SKIMMER™ – Stack mounted device that traps liquid effluent traveling up stack walls.

PURIFIER™ – High velocity, in-line cyclonic mist eliminator incorporating a self-cleaning design.

PPS™ – Low maintenance, multi-stage mist eliminator for control of fine liquid particulate.

PPS/DBF™ – High-efficiency mist eliminator for control of sub-micron liquid particulate and opacity in oil mist applications.

COOLANT ABSORPTION – Heavy oil absorption/distillation process for the control of hydrocarbon (VOC) gases.

OXIDIZER – Thermal and catalytic oxidizing unit for destruction of hydrocarbons and (VOC) gases.

WET SCRUBBER – Particulate control systems for steel hot rolling, Steckel mills, and other metals industry applications.



BUSCH International continues to expand our users list of successful strip cooling and drying installations in the metals industry. The **JET★STAR™** strip cooler is designed to cool heavier gauge strip with thicker coatings, at higher strip speeds, using less energy than other cooling methods. The **JET★STAR™** dryer produces predetermined wiping patterns on the surface to rapidly and uniformly dry the strip. The **JET★STAR™** strip blow-off system quickly removes residual liquids from the strip. The **JET★STAR™** coil cooler reduces the cooling process from days to hours. The patented **JET★STAR™** technology is flexible and can accommodate most cooling, drying and blow-off needs.

JET★STAR™ Strip and Coil Coolers

AIR COOLER – Patented strip cooling system featuring high efficiency, uniform cooling, and enhanced strip stabilization. Uses include after pot cooling for hot dipped galvanizing lines, coating, annealing and silicon steel lines.

AIR/WATER COOLER – Patented highly effective means to supply cooling air and water to the strip to achieve increased, yet uniform heat transfer capability while containing the water within the cooler. Available for vertical and horizontal installations.

STRIP DRYER – Strip drying systems for chemical treatment, cleaning and galvanizing lines, continuous anneal and pickling applications, and other metal processing facilities.

COIL COOLER – Unit efficiently cools single or multiple metal coils, using patented flexible **JET★STAR™** nozzles for ease of access for coil handling.

STRIP BLOW-OFF – Strip, slab and metal product blow-off units for heavy industry.

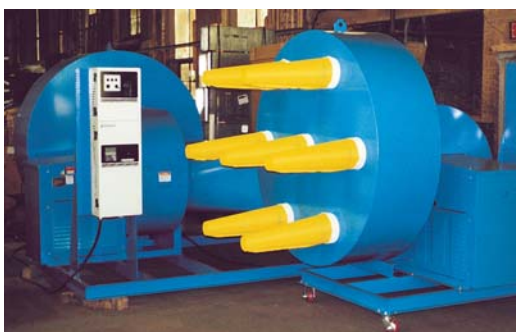
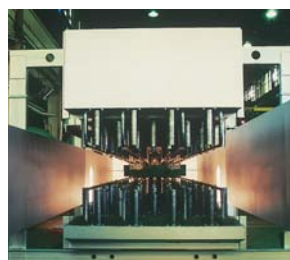
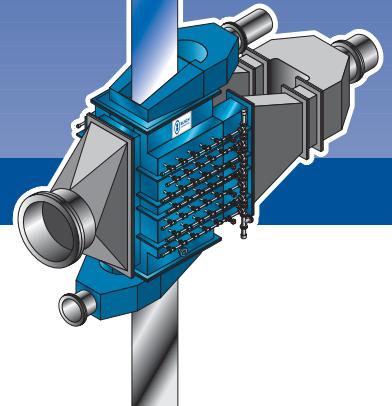



BUSCH International is an equipment supplier specializing in air-related applications. We employ an engineering staff experienced in aerodynamic, thermodynamic, mechanical, civil, and electrical disciplines. Unlike most other companies, these personnel are utilized entirely to support our air systems work. Areas of expertise include evaporative cooling, DC drive motor ventilation, gas adsorption, scrubbers, turbine inlet filtration, acoustics and corrosion control. We are available to provide custom equipment and services to meet your specific requirements.

Other Products and Services

IFC™ – Inlet Filtration Compartment incorporating self-cleaning or replaceable filters for gas turbines and large compressors.

SIMPULSE™ – Air filtration unit incorporating self-cleaning filters for small compressors.

PULPITS – Custom-engineered heavy-duty enclosure for personnel and equipment.

STUDIES – Evaluation of problems associated with the ventilation of electrical equipment, pressurization and cooling of control/motor rooms, rolling mill fume exhaust, hoods for smoke and dust, strip cooling/drying, and other related topics.

FIELD SERVICES – Air Flow Testing and System Emissions Testing. Other field services related to our core business.

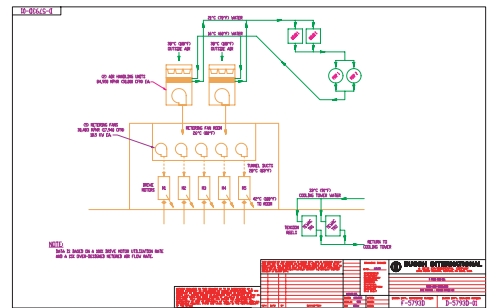
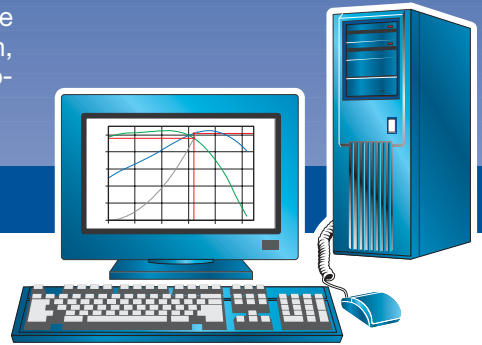



CECO Abatement
4444 Lee Avenue
Downers Grove, IL 60515
Phone: 630.493.0624
Fax: 630.493.1837
sales@cecoabatement.com
www.cecoabatement.com

CECOaire
1450 S. 15th Street
Louisville, KY 40210
Phone: 502.635.2655
Fax: 502.637.4687
info@cecoaire.com

CECO Filters, Inc.
1029 Conshohocken Road
Conshohocken, PA 19428
Phone: 610.825.8585
Fax: 610.825.8506
Toll Free: 800.220.8021
sales@cecofilters.com
www.cecofilters.com

KBD Technic
3131 Disney Street
Cincinnati, OH 45209
Phone: 513.351.6200
Fax: 513.351.4071
info@kbd-technic.com
www.kbd-technic.com

Kirk and Blum
Cincinnati, OH
3120 Forrer Street
Cincinnati, OH 45209
Phone: 513.458.2600
Fax: 513.458.2647
Toll Free: 800.333.5475
info@kirkblum.com
www.kirkblum.com

Columbia, TN
1761 North Pointe Road
Columbia, TN 38401
Phone: 931.381.0037
Fax: 931.381.2241
kbtenn@kirkblum.com

Defiance, OH
1712 Spruce Street
Defiance, OH 43512
Phone: 419.782.9885
Fax: 419.782.9888
kblef@kirkblum.com

Greensboro, NC
8735 West Market Street
Greensboro, NC 27409
Phone: 336.668.3773
Fax: 336.668.9779
nckirkblum@kirkblum.com

Indianapolis, IN
3501 W. Kelly Street
Indianapolis, IN 46241
Phone: 317.244.3383
Fax: 317.243.1244
Toll Free: 800.678.5475
kb.indy@kirkblum.com

Lexington, KY
550 Horton Court
Lexington, KY 40511
Phone: 859.254.0386
Fax: 859.253.2586
Toll Free: 800.234.5475
kblex@kirkblum.com

Busch International

10431 Perry Highway
Wexford, PA 15090
Phone: 724.940.2326
Fax: 724.940.4140
info@buschintl.com
www.buschintl.com

The BUSCH Advantage:

Busch International, Pittsburgh, PA. Designs and builds air handling equipment and systems for filtering, cooling, heating, and capture of emissions in the metals industries. BUSCH International...is a quality oriented company, with a long history of service to steel, aluminum, chemical, paper, glass, cement, and power generation customers. In addition to a complete line of custom engineered, precision-manufactured products, BUSCH International provides a wide range of special services – including conceptual studies, application engineering, field services and system start-up.

CECO Abatement, Downers Grove, IL. Designs and builds thermal oxidizer systems.

CECO Filters, Conshohocken, PA. Manufacturer of fiber bed filter mist eliminator systems and scrubber systems.

KBD Technic, Cincinnati, OH. Offers emissions compliance testing through complete system design. The industrial ventilation engineering company.

Kirk & Blum, Cincinnati, OH. Offers solutions from custom dust and fume control systems to complete turnkey design-build services as a prime ventilation contractor.

CECO Environmental... Since 1907

CECO Environmental

3120 Forrer Street
Cincinnati, OH 45209
Phone: 513.458.2600
Fax: 513.458.2647
Toll Free: 800.333.5475
www.cecoenviro.com
info@cecoenviro.com
NASDAQ: CECE



CECO Environmental